

# ***Industrial robots and their integration with vision systems***

State of art and future developments

DAY 1

**Dott. Ing.Fabio Tampalini, Ph.D.**

Senior Technical Manager

DENSO @K.L.A.IN robotics srl



- Premessa
  - K.L.A.IN. robotics
  - DENSO
- Vision systems
  - Theory
  - Examples
- Software instruments
  - Presentation
  - Examples
- Conclusion and Q&A

# ***K.L.A.IN. Robotics srl***

**K.L.A.IN.** robotics



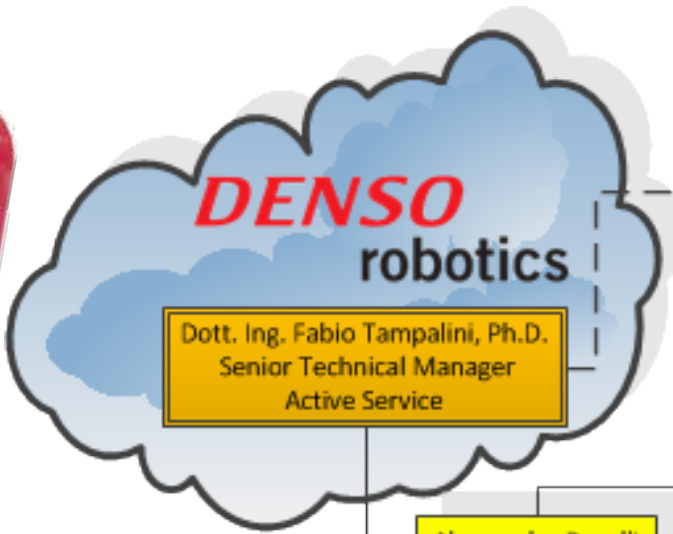

**K.L.A.IN. robotics s.r.l.**  
Sede Leg.: Via F.lli Porcellaga, 3 - 25122 Brescia  
Sede Amm./Op.: Via Cacciamali, 67 - 25125 Brescia  
PARTITA I.V.A. n° 03219670985  
Tel. 030.35.82.154 - Fax 030.26.59.911

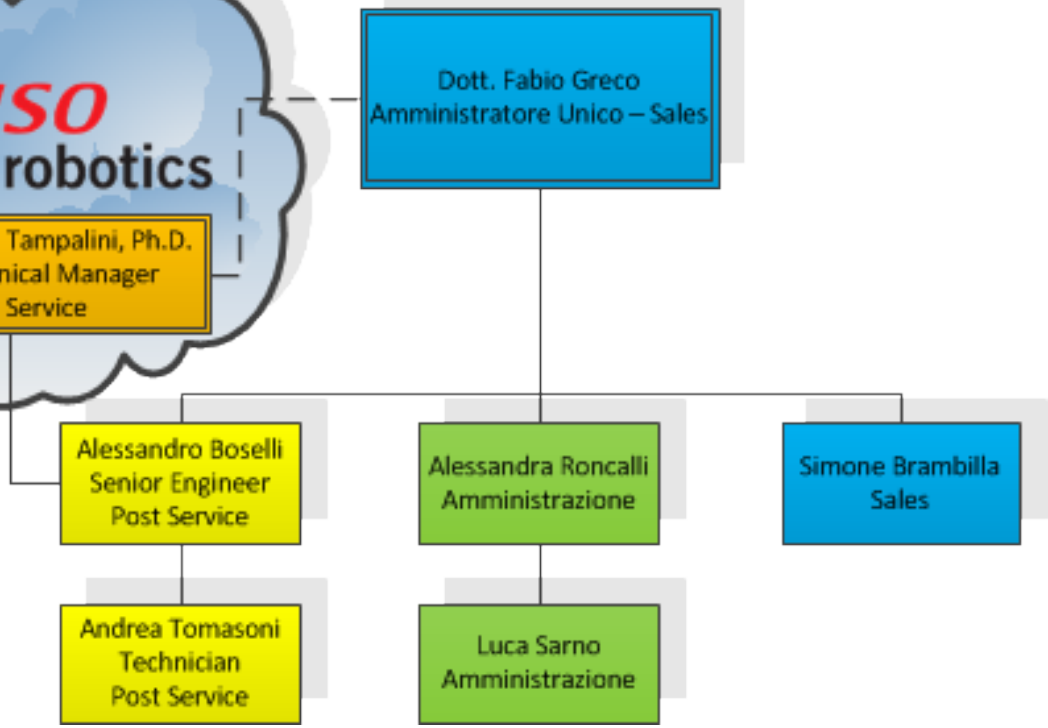

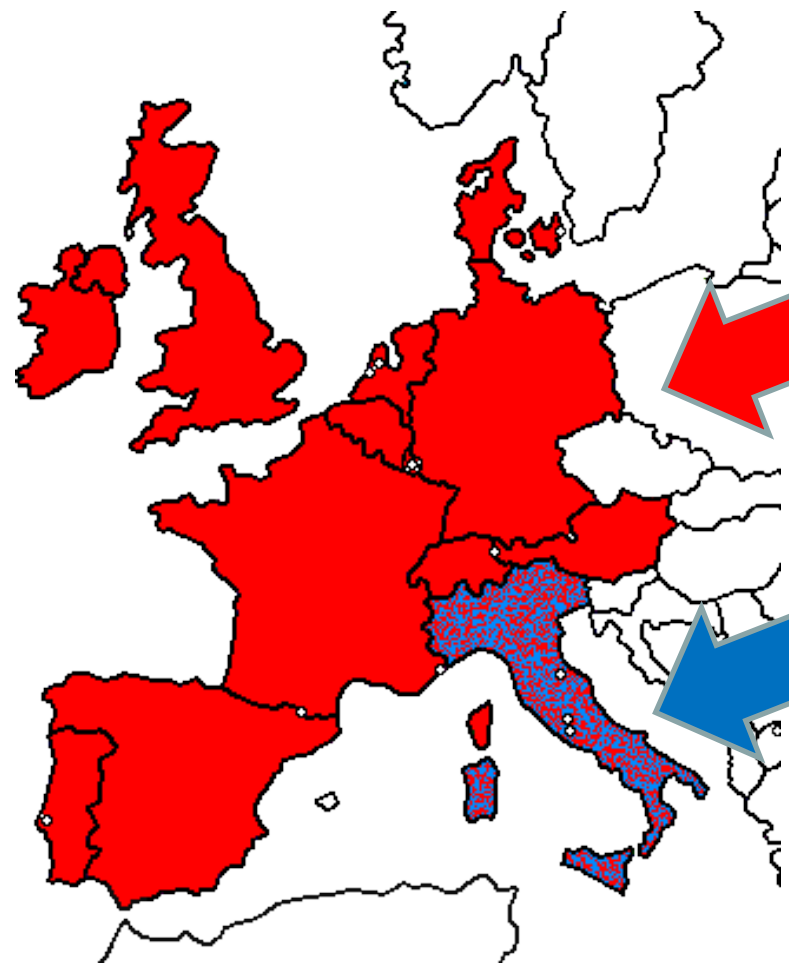

***DENSO***  
robotics

























**K.L.A.I.N.** robotics

- La società K.L.A.IN. robotics s.r.l., con sede a Brescia, dal 1999 distribuisce sul mercato italiano i robot della gamma Denso e dall'inizio del 2011 anche i robot Hyundai
- La sua attività si articola principalmente su due fronti:
  - Il primo è la **fornitura di prodotti per l'automazione** a System Integrator specializzati che operano prevalentemente nella realizzazione di linee di assemblaggio, ma anche nei diversi settori applicativi della manipolazione e dell'asservimento di macchine operatrici in generale.
  - Il secondo fronte di **attività è l'assistenza e la formazione** in staff alla clientela durante l'installazione e la fase di start-up di queste automazioni nell'ambito degli impianti realizzati, formazione volta all'ottimizzazione sia della programmazione che del ciclo e prestazione del robot.



# HYUNDAI

HEAVY INDUSTRIES CO., LTD.

Model												
	HA006	HA010L	HA020	HH030L	HH050	HR050P	YS080	YS100	HH100SL	HH130L	HS150L	
Payload	6 kg	10 kg	20 kg	30 kg	50 kg	50 kg	80 kg	100 kg	100 kg	130 kg	150 kg	
Max. Reach	1,394 mm	1,986 mm	1,765 mm	2,535 mm	2,239 mm	2,041 mm	2,239 mm	1,701 mm	3,507 mm	3,082 mm	3,082 mm	
Degree of freedom	6 Axes	6 Axes	6 Axes	6 Axes	6 Axes	3 Axes	6 Axes	6 Axes	6 Axes	6 Axes	6 Axes	
												
HP160	HS165D	HS165C	HS165	HS165S	HS200	HS200S	HX200L	HX300	HX300L	HX400	HX400S	HX500
160 kg	165 kg	165 kg	165 kg	165 kg	200 kg	200 kg	200 kg	300 kg	300 kg	400 kg	400 kg	500 kg
3,128 mm	1,355 mm	866 mm	2,666 mm	3,090 mm	2,666 mm	3,090 mm	3,056 mm	2,573 mm	3,056 mm	2,573 mm	3,106 mm	2,573 mm
4 Axes	6 Axes	5 Axes	6 Axes	6 Axes	6 Axes	6 Axes	6 Axes	6 Axes	6 Axes	6 Axes	6 Axes	6 Axes

# ***DENSO Robotics***

## **„Company & Product Introduction“**

**June 2011**







**Founded**

16 Dec. ,1949

---

**Net sales** (April 1<sup>st</sup>, 2010 – March 31<sup>st</sup>, 2011)

Consolidated

37.7 bill. \$

---



**Employees** (March 31<sup>st</sup>, 2011)

Consolidated

Around 120 000

---

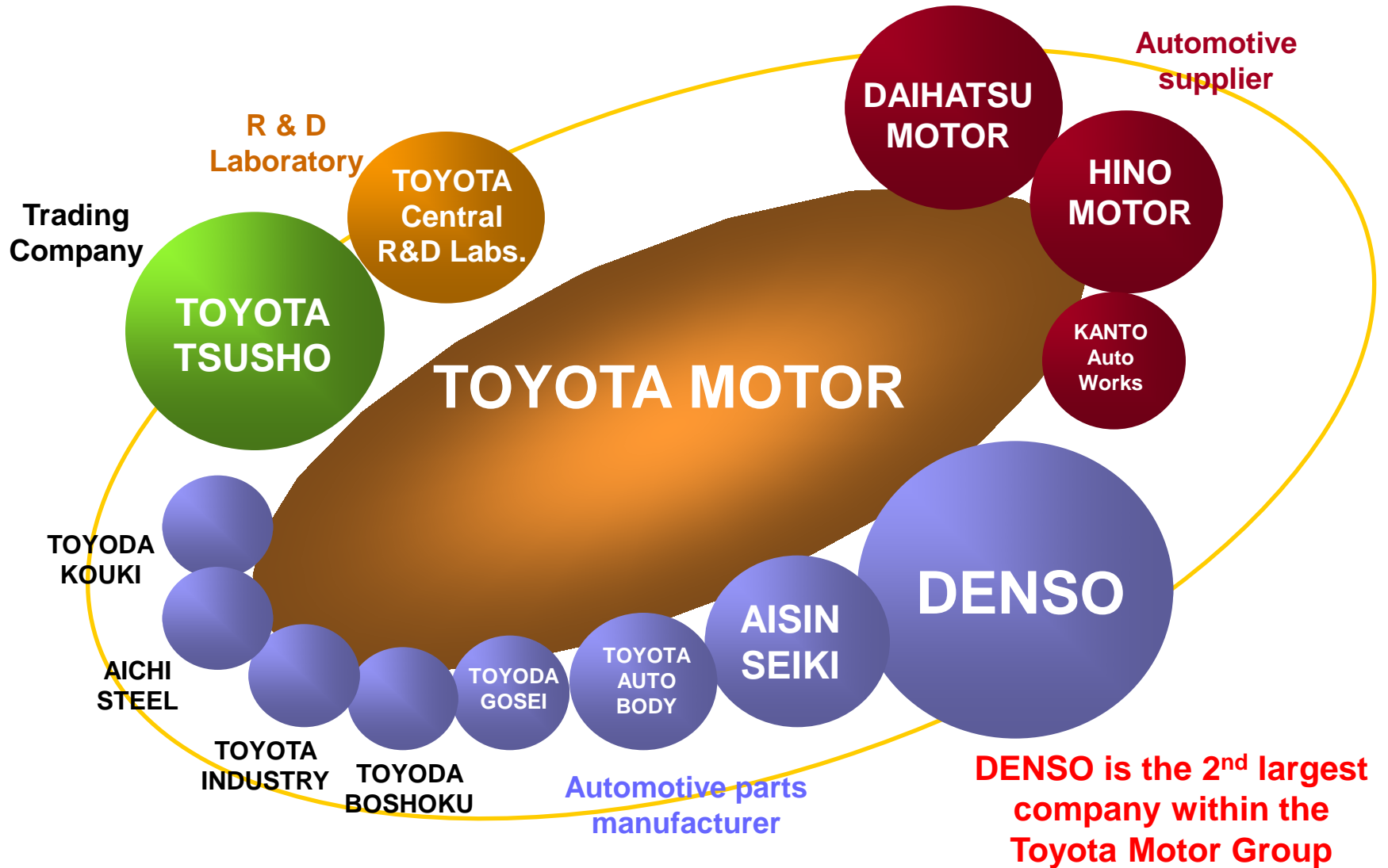

## Engine Related Products

Engine management system,  
Electronically-controlled diesel system,  
Starter, Alternator, Radiator, etc.

## Climate Control Products

Automatic air conditioner, Car heater,  
Rear cooling unit, Compressor,  
Sensors, etc.

## Body Electronics Products

Instrument cluster, Windshield wiper  
Remote keyless entry system,  
IC flasher, Horn, etc.

## Driving Control and Safety

Antilock braking system, Traction control system,  
Cruise control system, Airbag sensing system,  
Vehicle stability control, etc.

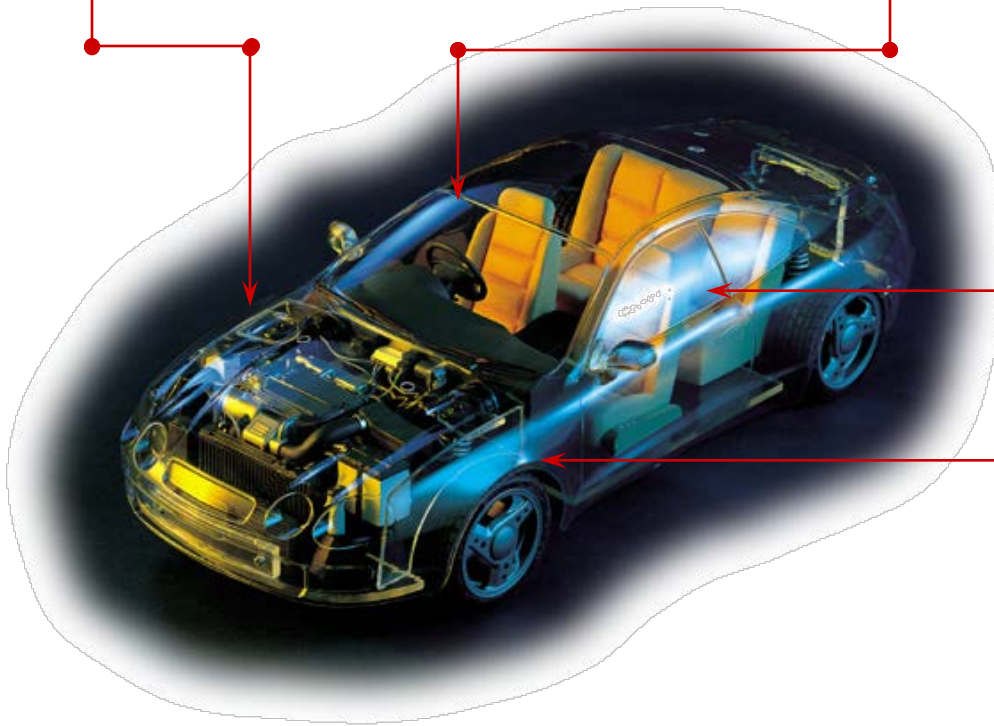

## DENSO EUROPE B.V.

Weesp, Netherlands (30 minutes away from Amsterdam Airport)

- **Administration**

EUROPE – FOCUS

- **F & A**

- **Logistic**

- **Warehouse**

- Robots

- Accessories

- Spare parts

- **Repair Center**

- Repair

- Maintenance



## DENSO Robotics

Moerfelden-Walldorf, Germany

(20 minutes away from Frankfurt Airport)

EUROPE – FOCUS

- Management / Marketing
- Sales Europe
- Order Handling
- SW + Application support
- Service & Support Hotline
- Application Laboratory
- Training
- ORiN2 Development & Support Center
- Stock for lease robots



## Dealers in:

- Spain (CONTAVAL)
- Italy (Klain Robotics)
- Denmark and Sweden (AVN)
- Finland (EID Tech) EUROPE – FOCUS
- Benelux (ROBA)
- UK and Ireland (AA Robotics)
- Turkey (iRob)
- Switzerland (Bachofen)



## Middle East:

- Israel (PROBO-TEC)



Middle East (Israel)

## Direct Sales in:

- Germany (Sales Office), Austria, and rest of Europe



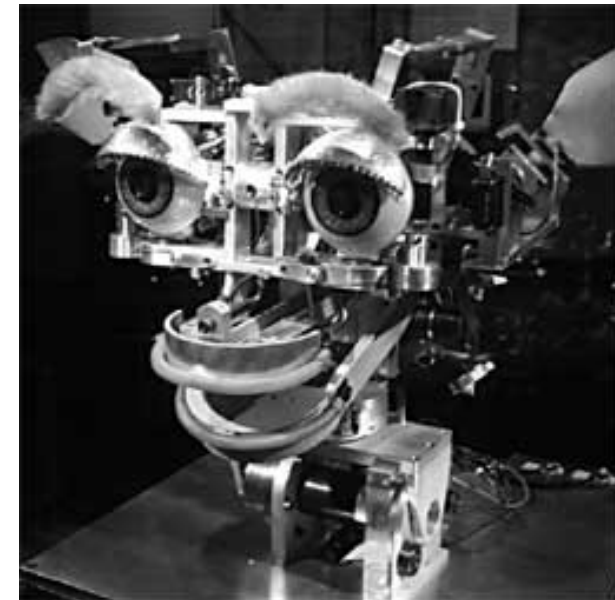





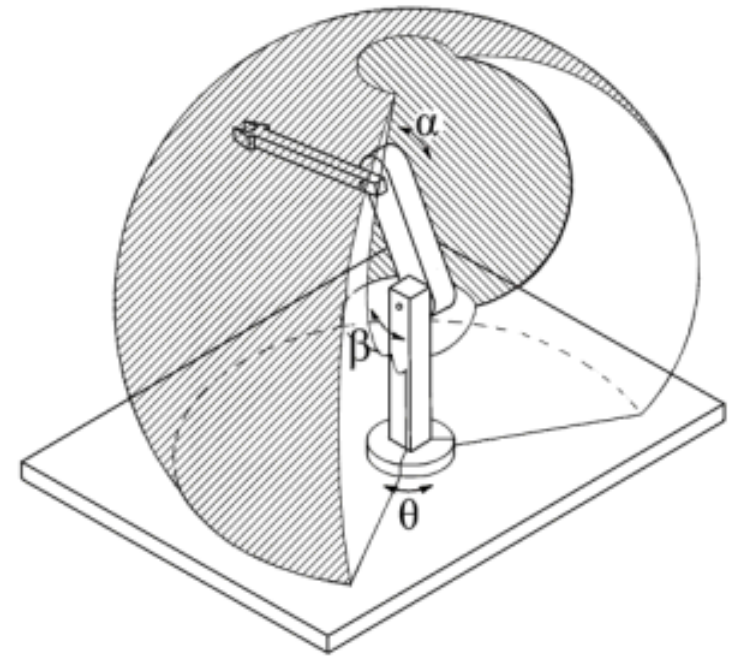

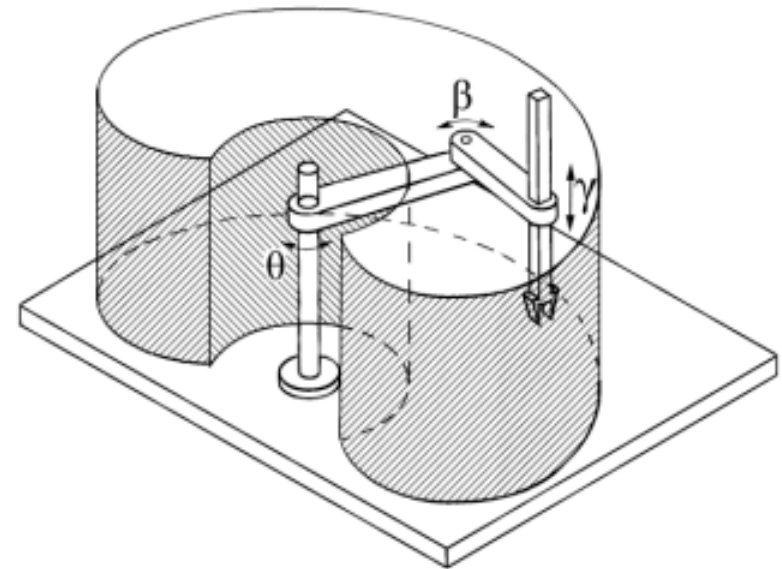

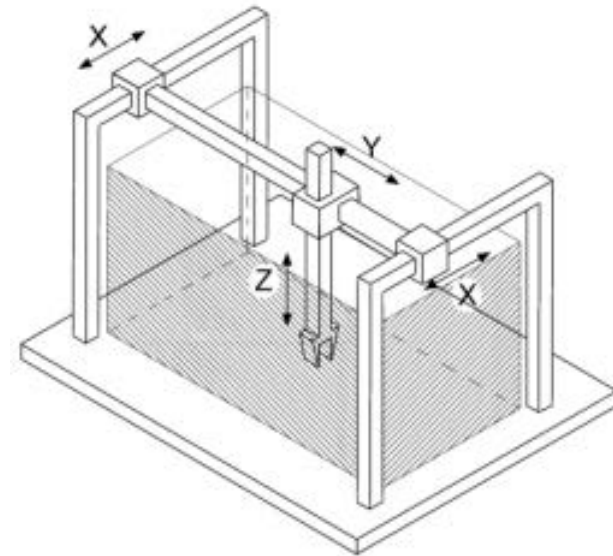
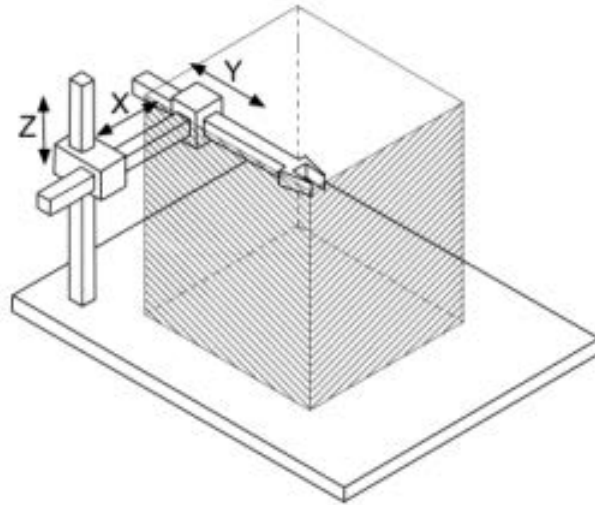

Cartesian Coordinate Robots

## XYC4-G Series

Compact size cartesian coordinate robots!  
Various choice for user's needs  
due to wide variations.



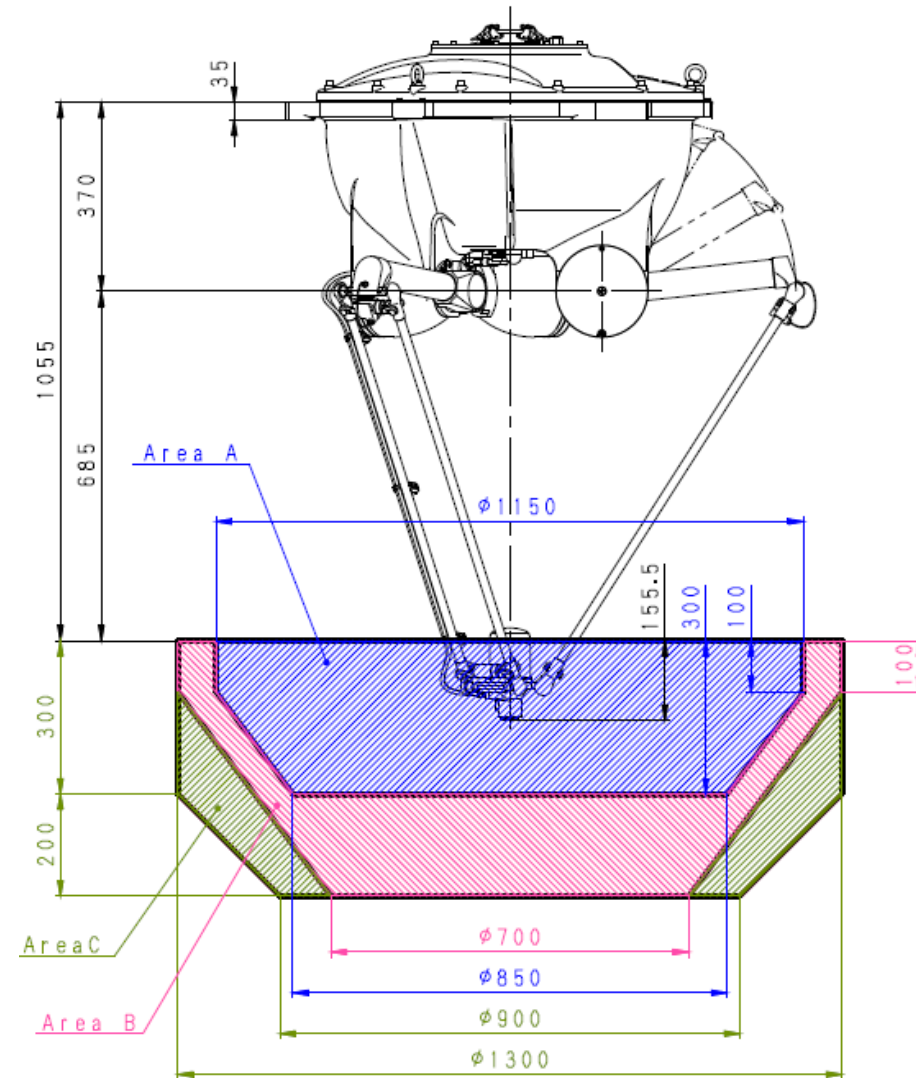

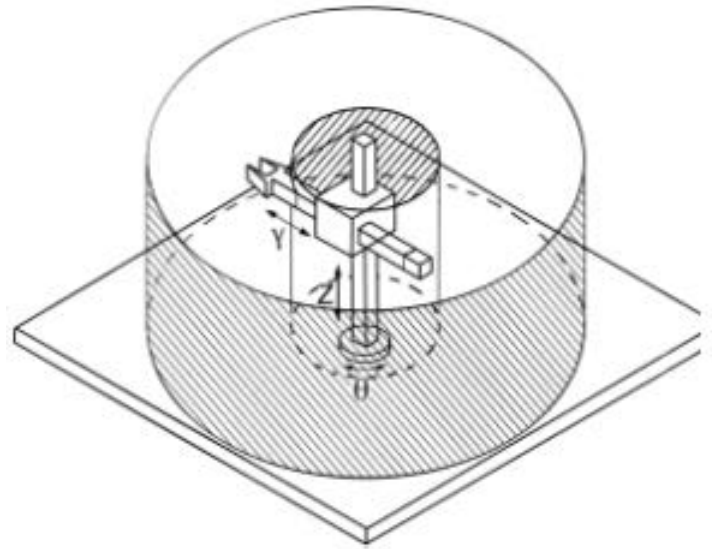
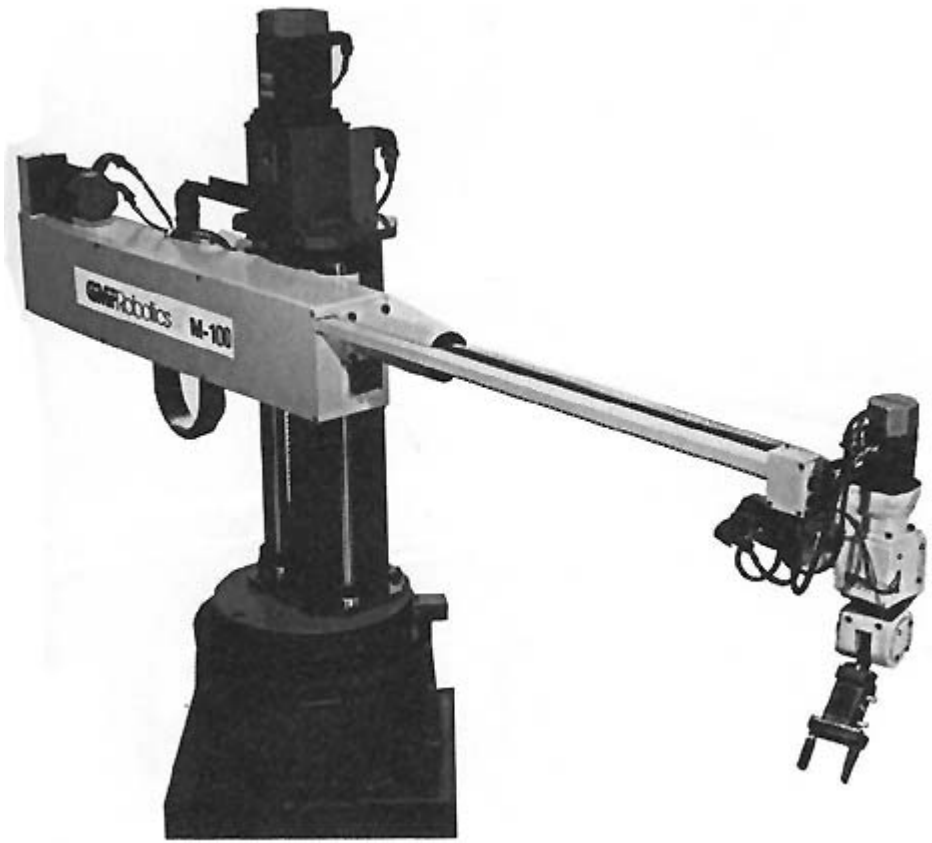

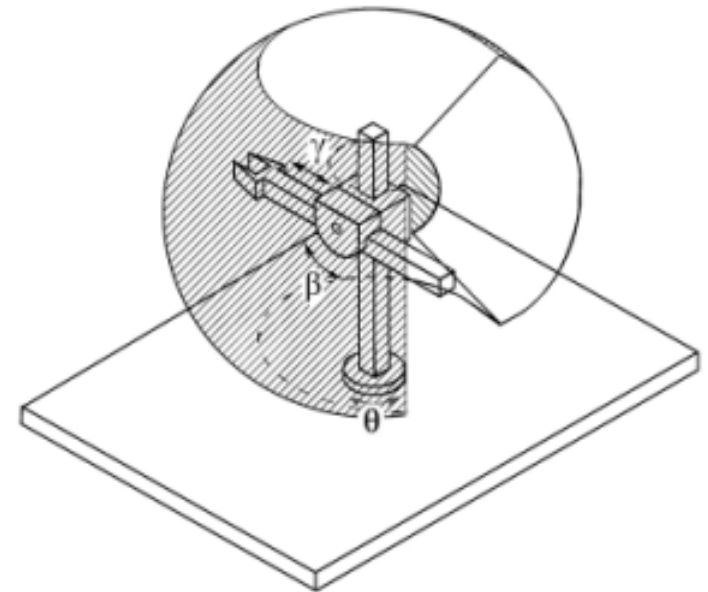
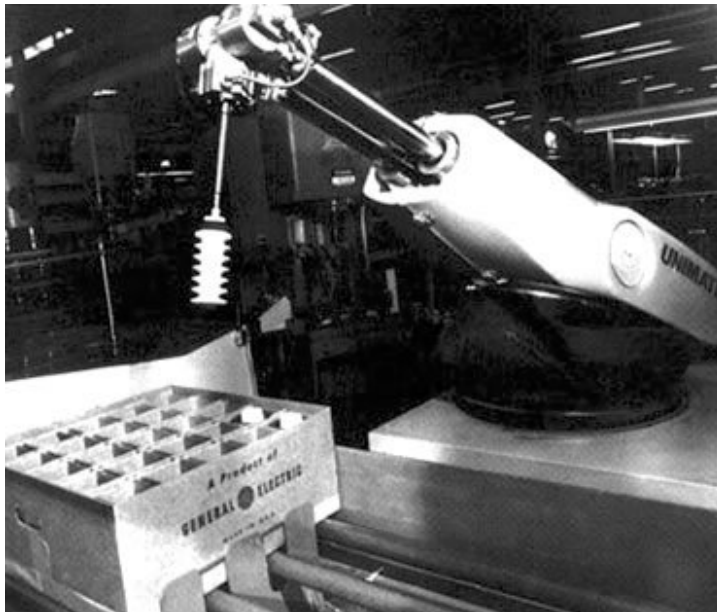



### ■ Applications

#### <Assembling & Handling>

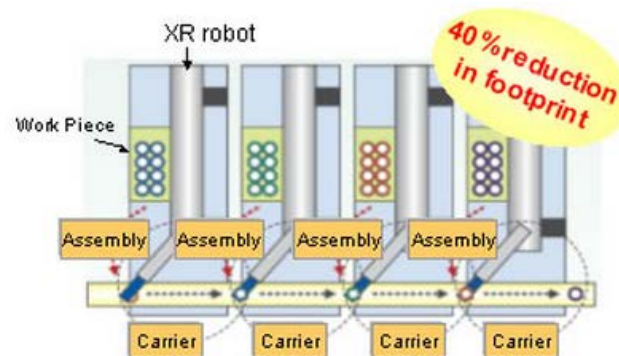

- **Compact**  
Reduced width of equipment and shortened production lines
- **Lower Investment**  
Eliminate additional devices to lower cost

#### <Feeding & Carrier>

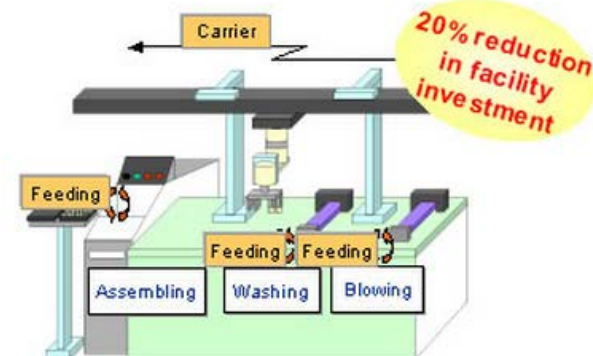

- **Compact**  
Reduced width with ceiling mountable structure
- **Flexibility**  
Programmable and flexible in feeding/ conveying movements

### ■ High speed

17% faster than our conventional Cartesian robots with combined move of coordinated slide and swivel motions.

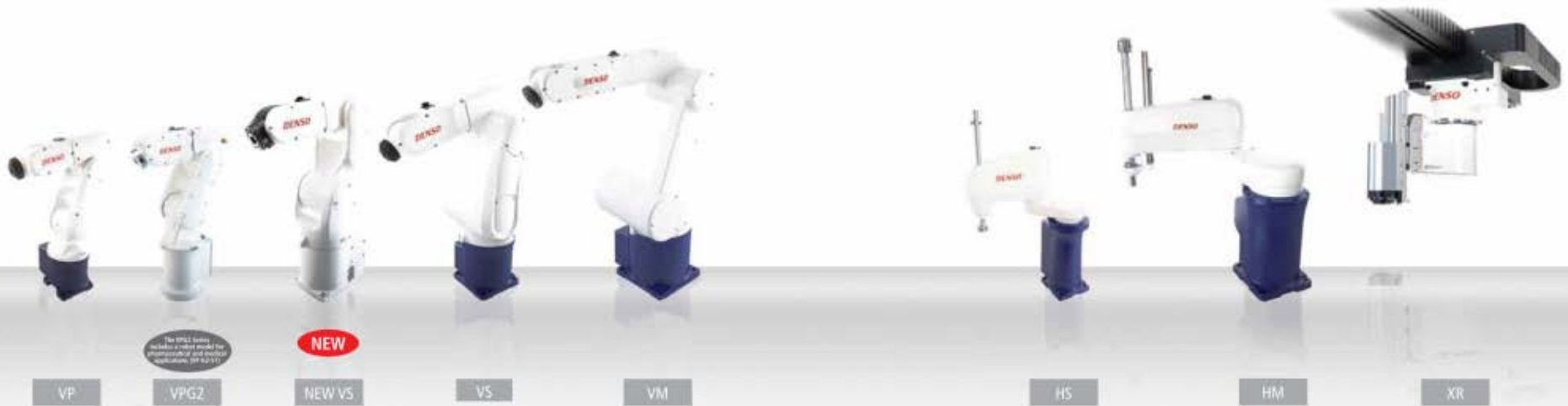

## 6-AXIS ROBOTS /

### Ideal for:

- Assembly
- Inspection
- Matching
- Material handling
- Machine tending
- Packaging
- Palletizing
- Electrostatic welding
- Bespoke applications

### Industries:

Our robots are employable in a wide variety of industries including pharmaceutical, medical and food.

### Available in Protection Classes:

- Standard
- Dust & Splash Proof (IP65)
- Protected (IP67)
- Clean Room Class 10 & 100
- Hydrogen Peroxide-resistant (H<sub>2</sub>O<sub>2</sub>) for aseptic environments
- UL Specifications (for the USA and Canada)

### Main features:

- Payloads up to 10 kg
- Arm reach up to 1300 mm
- Max. Comp. Speed up to 11 000 mm/s
- Mounting in floor, ceiling and wall

## 4-AXIS ROBOTS /

### Ideal for:

- Pick & place
- Assembly
- Packaging
- Dispensing
- Inspection
- Material removal
- Material handling
- Bespoke applications

### Industries:

Our robots are employable in a wide variety of industries including pharmaceutical, medical and food.

### Available in Protection Classes:

- Standard
- Dust & Splash Proof (IP65)
- Clean Room Class 10
- UL Specifications (for the USA and Canada)

### Main features:

- Payloads up to 20 kg
- Arm reach up to 1000 mm
- Max. Comp. Speed up to 11 500 mm/s
- Mounting in floor and ceiling



### GAMMA ROBOT SCARA DENSO

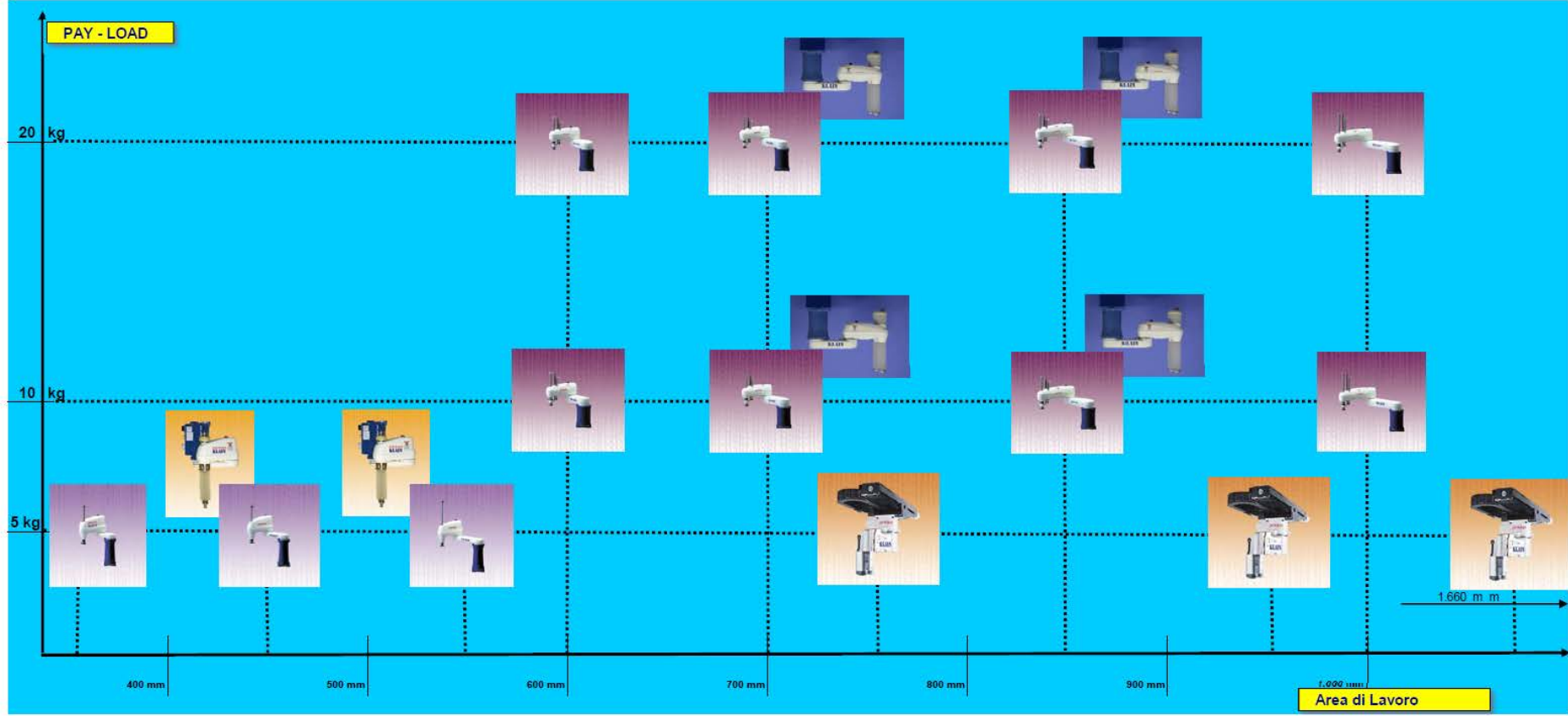

### GAMMA ROBOT ANTROPOMORFI DENSO

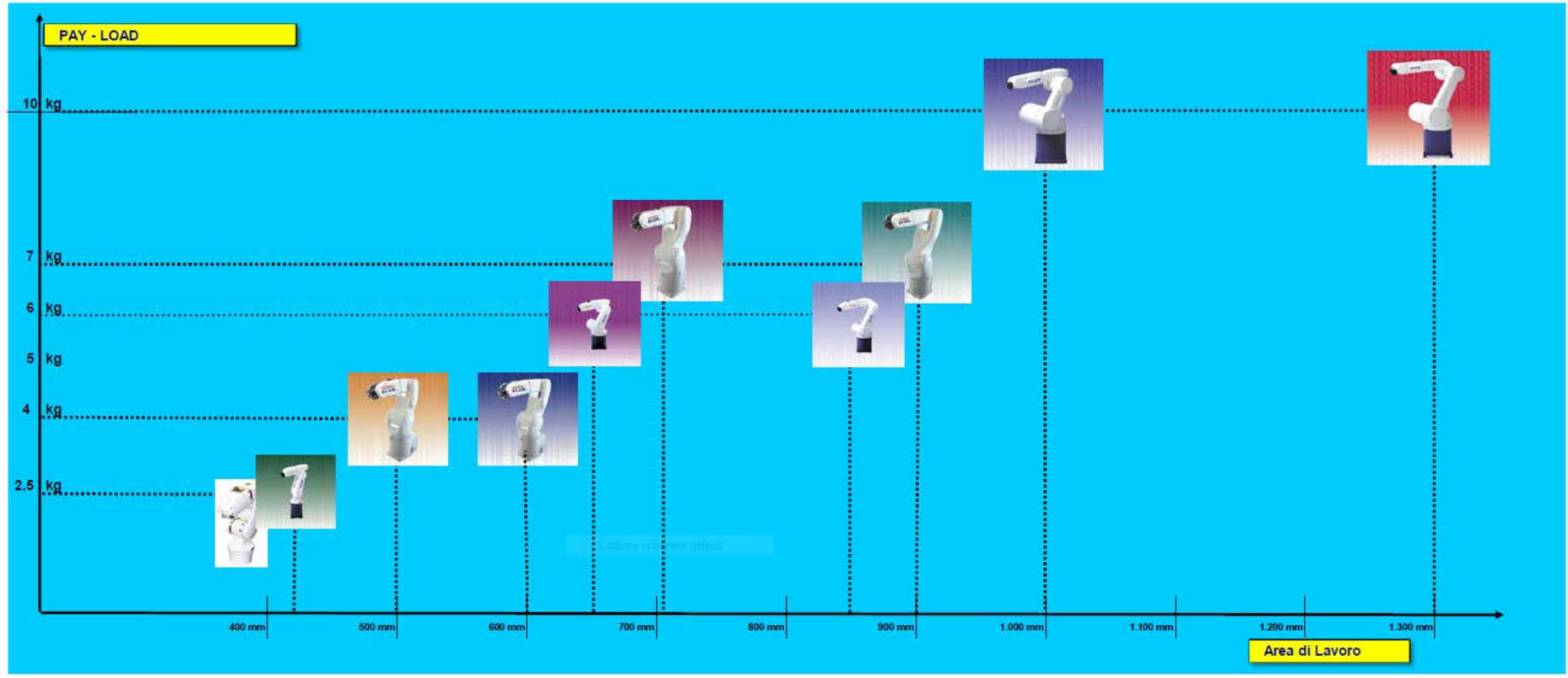

## Maintainability

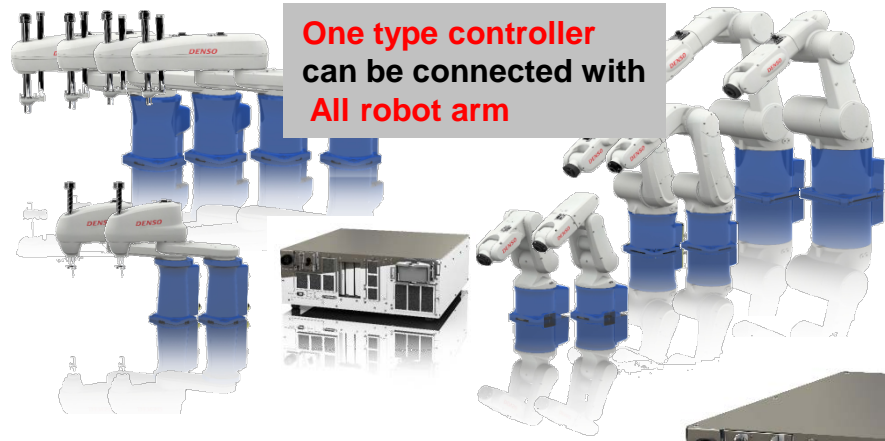

**One type controller can be connected with All robot arm**

## Extendibility

Standard:	Option:
Mini I/O 16 / 16	Extension I/O board 40(80) / 48(96)
Hand I/O 8 / 8	RS-232C +2ch
1 x Ethernet (100 Base)	Profibus Slave 256 / 256
2 x USB	DeviceNet Slave 256 / 256
1 x RS-232C	DeviceNet Master 1024 / 1024
	DeviceNet Master & Slave
	Conveyor tracking



## MODE Select KEY



## Safety Circuit

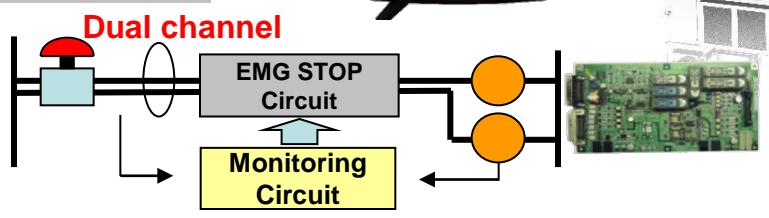

## Lock out

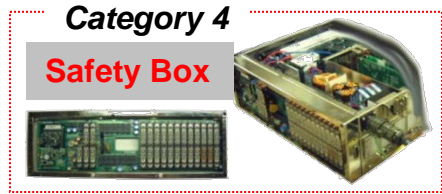

## Panel Designer for Windows



**Display 7.5 inch  
Dust & Splash proof IP65**

## Safety

## Usability

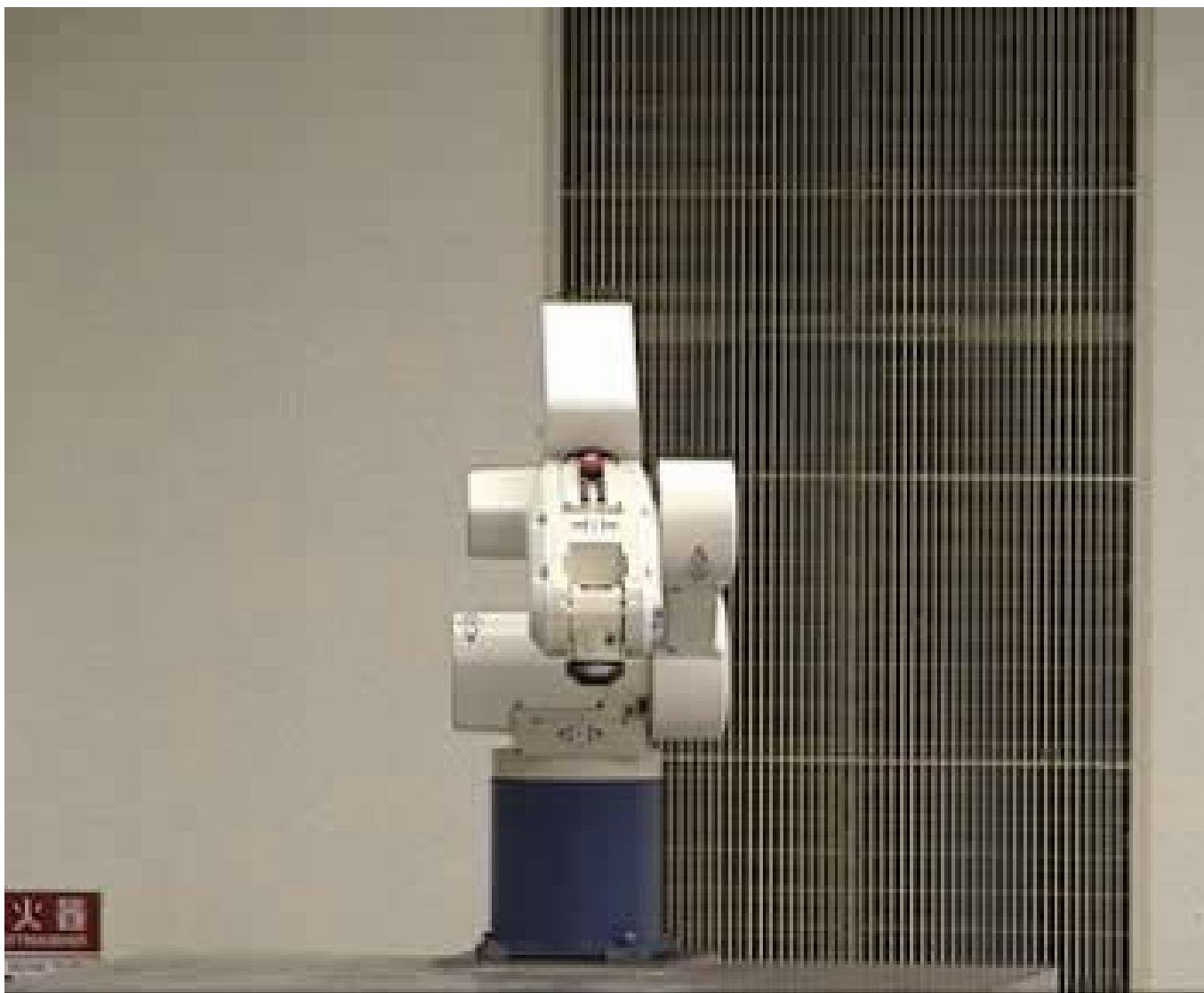





- DENSO Robotics

- La griglia rappresenta l'insieme delle posizioni raggiungibili cioè la risoluzione spaziale.
- La posizione insegnata è quella presa sul campo che viene memorizzata come variabili di giunto.
- L'errore di posizionamento dipende dall'accuratezza del modello cinematico.
- L'accuratezza del modello cinematico dipende da parametri geometrici (tolleranze) cedevolezza, etc.
- E' più facile costruire robot ripetibili piuttosto che robot accurati.

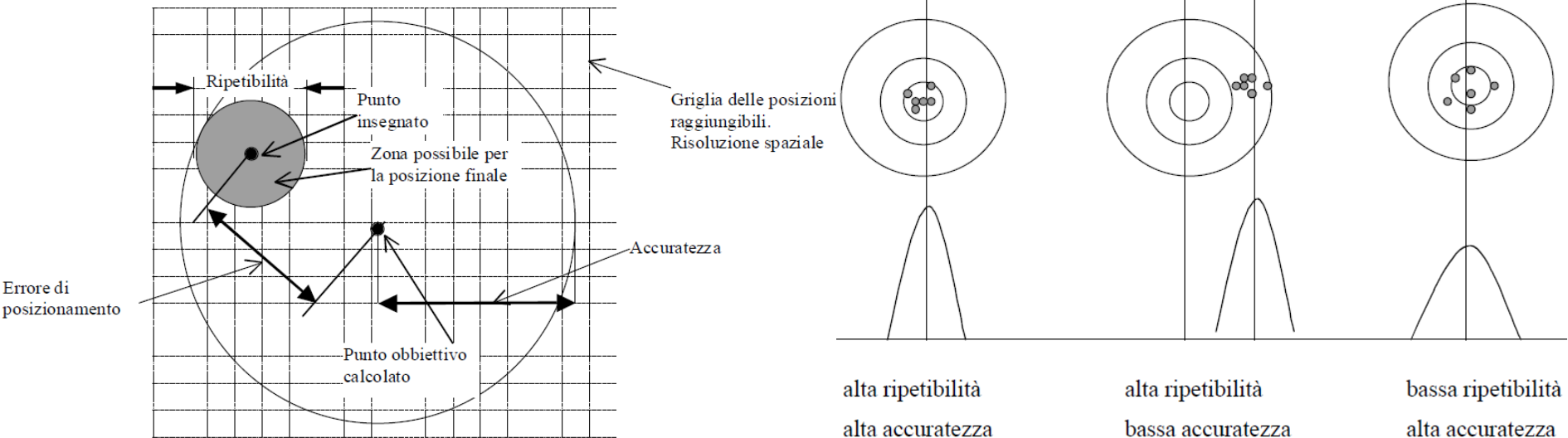



- Esistono diversi modi per risolvere semplicemente questo punto:
  - Eseguire una adeguata calibrazione tra isola reale e isola virtuale
  - Usare robot detti “high accuracy robot”
  - Usare strumenti che correggono le discrepanze tra virtuale e reale direttamente durante il ciclo di lavoro (si pensi all’inseguimento giunto laser per isole di saldatura)



# La visione nella robotica industriale



## Una possibile configurazione



## Interazione con l'ambiente:

- Un robot si trova comunemente ad interagire con l'ambiente di lavoro, manipolando oggetti o compiendo operazioni su superfici.
- L'ambiente circostante di norma pone dei vincoli di natura geometrica al moto del manipolatore.
- Utilizzare in queste condizioni una strategia di controllo puramente posizionale può comportare problemi a seguito di errori di posizionamento e di incertezze nella pianificazione del compito, dovute ad una conoscenza non completa dell'ambiente.

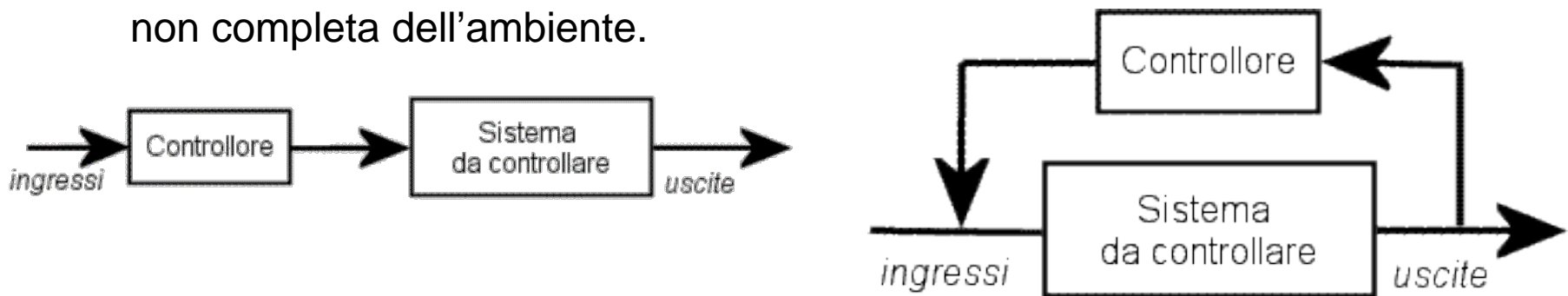

## Dove si può usare la visione?

- Asservimento
- Assemblaggio
- Pallettizzazione
- Inscatolamento
- Misura
- Lettura
- Ispezione
- Presenza/Assenza
- Qualità
- Sicurezza
- Sbavatura
- Verniciatura

**Misure visive:**

- Gli organi di visione artificiale sono sensori utili per la robotica poiché imitano il senso umano della vista e consentono misure dell'ambiente senza il contatto. Oggi esistono diversi controllori robotici che integrano sistemi di visione.
- Tipicamente la visione e la manipolazione vengono combinate in una tecnica ad anello aperto: il sistema di visione guida il sistema di controllo posizionale. Si parla in questo caso di tecniche **look-and-move**.
- Alternativamente, le misure visive possono essere utilizzate direttamente in un anello di retroazione per realizzare il controllo di posizione in anello chiuso dell'organo terminale. Si parla in questo caso di tecniche di **visual servoing**.

## Introduzione:

- Una **telecamera** è un dispositivo in grado di misurare l'intensità della luce, concentrata da una lente su un piano, il **piano immagine**, contenente una matrice di pixel i quali trasformano l'energia luminosa in energia elettrica.
- La telecamera effettua quindi una **proiezione 2D** della scena inquadrata. Questa proiezione causa una perdita delle informazioni di profondità: ciascun punto nel piano immagine corrisponde ad un raggio nello spazio 3D.

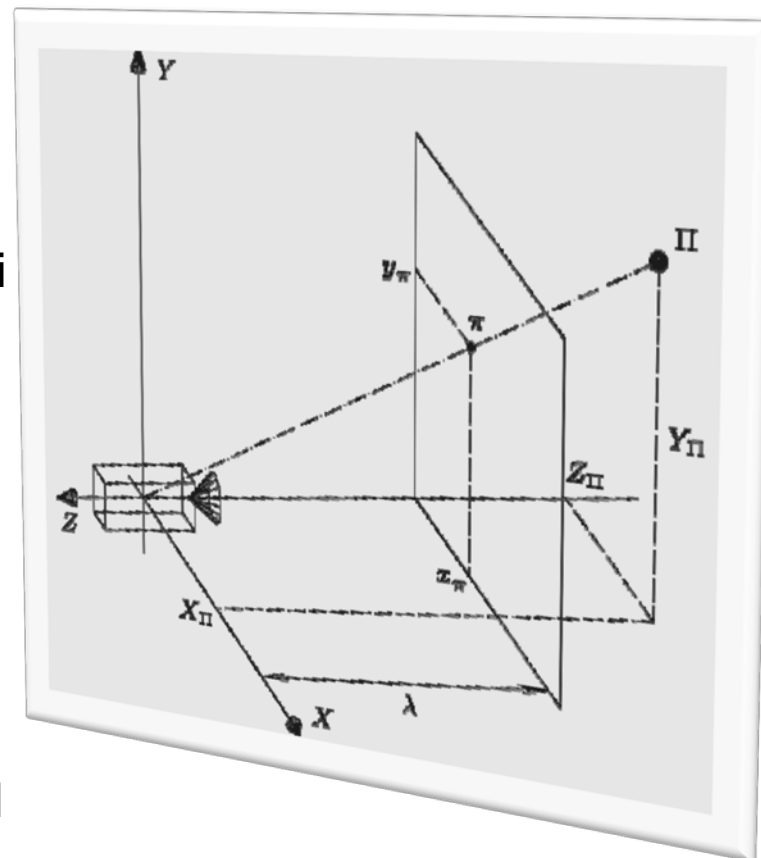

La telecamera utilizzata in un sistema di visione robotico deve essere calibrata.

**Calibrazione interna:** Determinazione dei parametri intrinseci della telecamera e di parametri addizionali di distorsione, dovuti ad imperfezioni della lente e a disallineamenti del sistema ottico.

**Calibrazione esterna:** Determinazione dei parametri estrinseci della telecamera quali la posizione e l'orientamento della telecamera rispetto ad un sistema di riferimento.



Griglia di punti

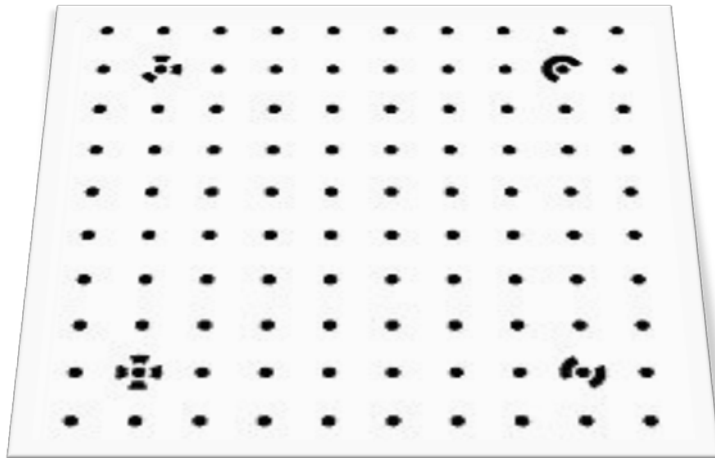

Piano cartesiano noto

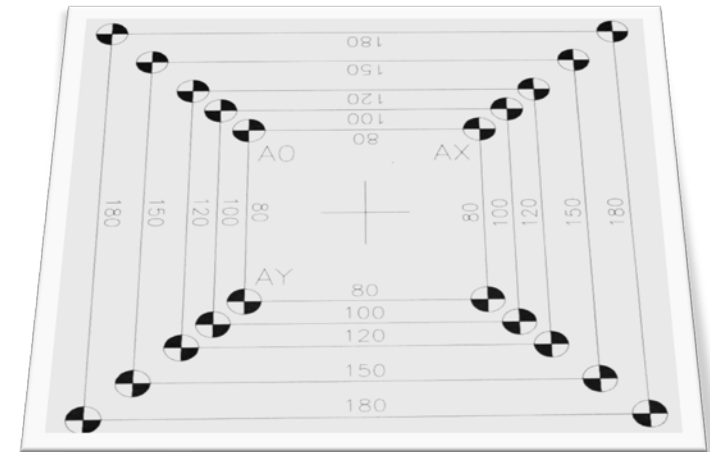

Scacchiera

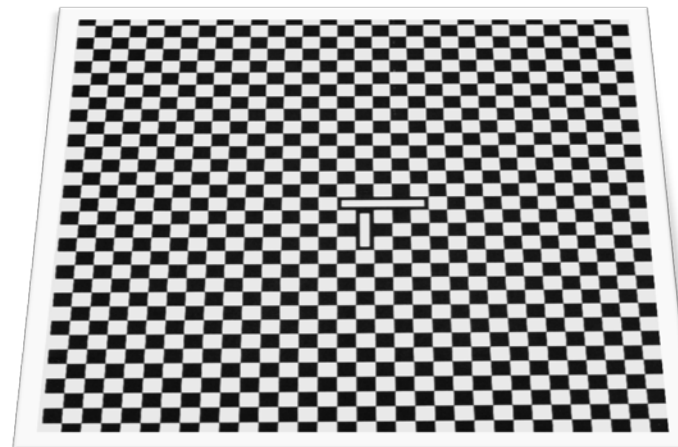

## La configurazione

### Eye in hand

La telecamera è montata sull'end effector: c'è una relazione fissa tra la posizione della telecamera e quella dell'end effector.



### Eye out hand

La telecamera è fissa nello spazio di lavoro.

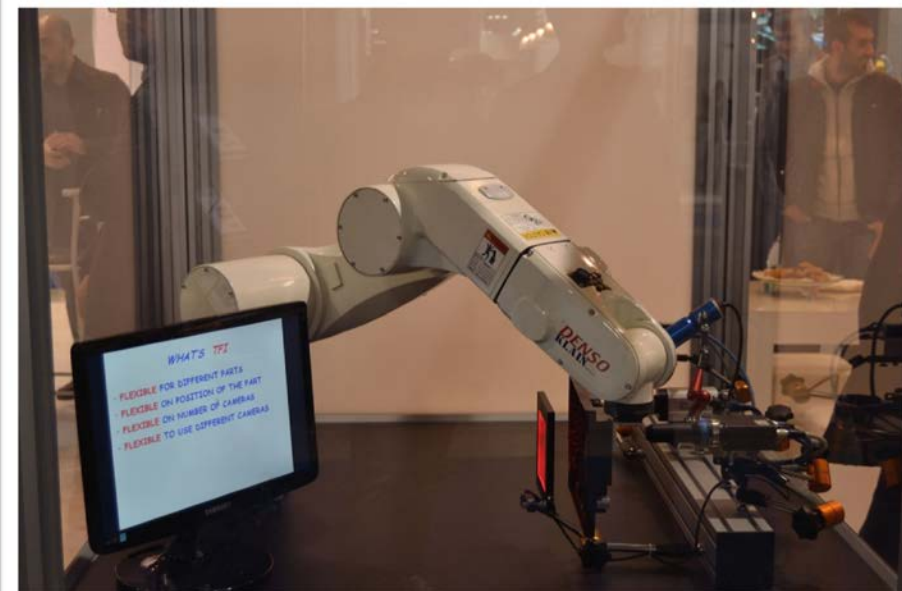

## Utilizzo

**Telecamere:** La macchina fotografica o fotocamera è lo strumento utilizzato per la ripresa fotografica e per ottenere immagini di oggetti reali archiviabili su supporti materiali o elettronici. La fotocamera in senso stretto, quella più nota e diffusa, lavora con la porzione dello spettro elettromagnetico visibile o luce ma può sfruttare altre porzioni spettrali, o differenti forme di energia, riflesse, emesse, diffuse o trasmesse dall'oggetto da rappresentare. (cit. Wikipedia)



## Utilizzo

**TOF:** A time-of-flight camera (TOF camera) is a camera system that creates distance data with help of the time-of-flight (TOF) principle which is different from time-of-flight mass spectrometry. The principle is similar to that of LIDAR scanners with the advantage that whole scene is captured at the same time. (cit. Wikipedia)

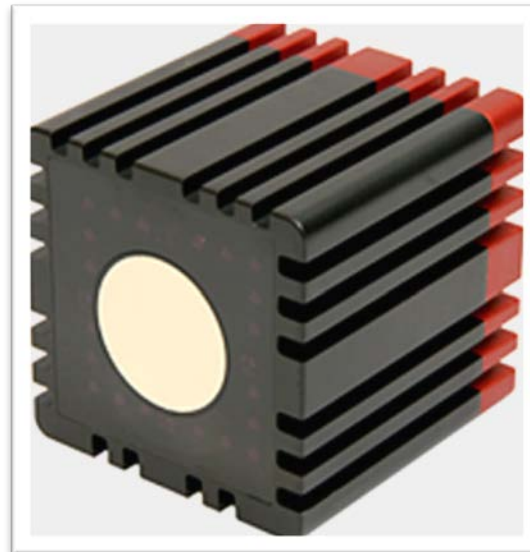

## Utilizzo

### Laser

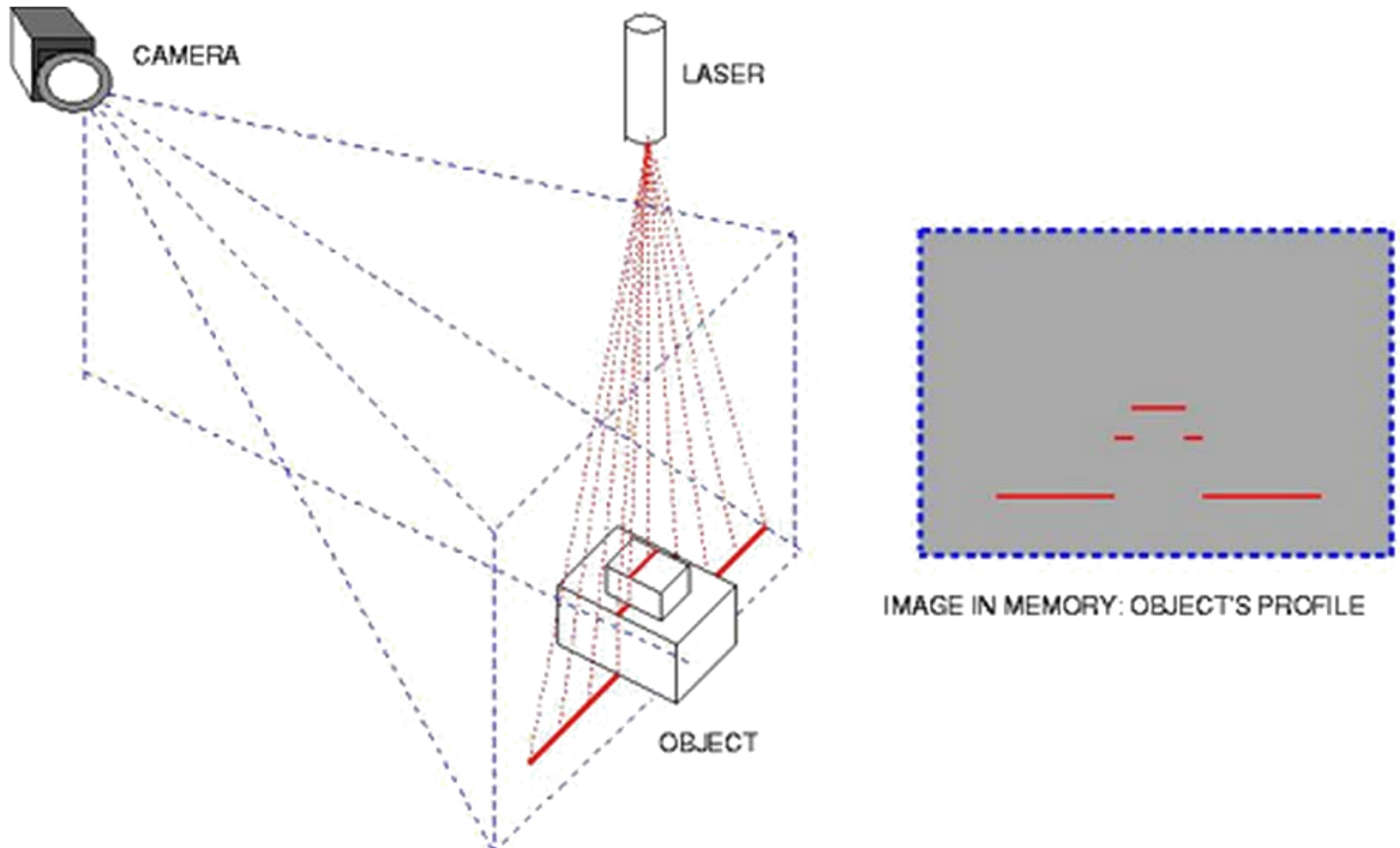

**Sensibilità:**

- Colore
- BN
- IR
- Ultravioletto

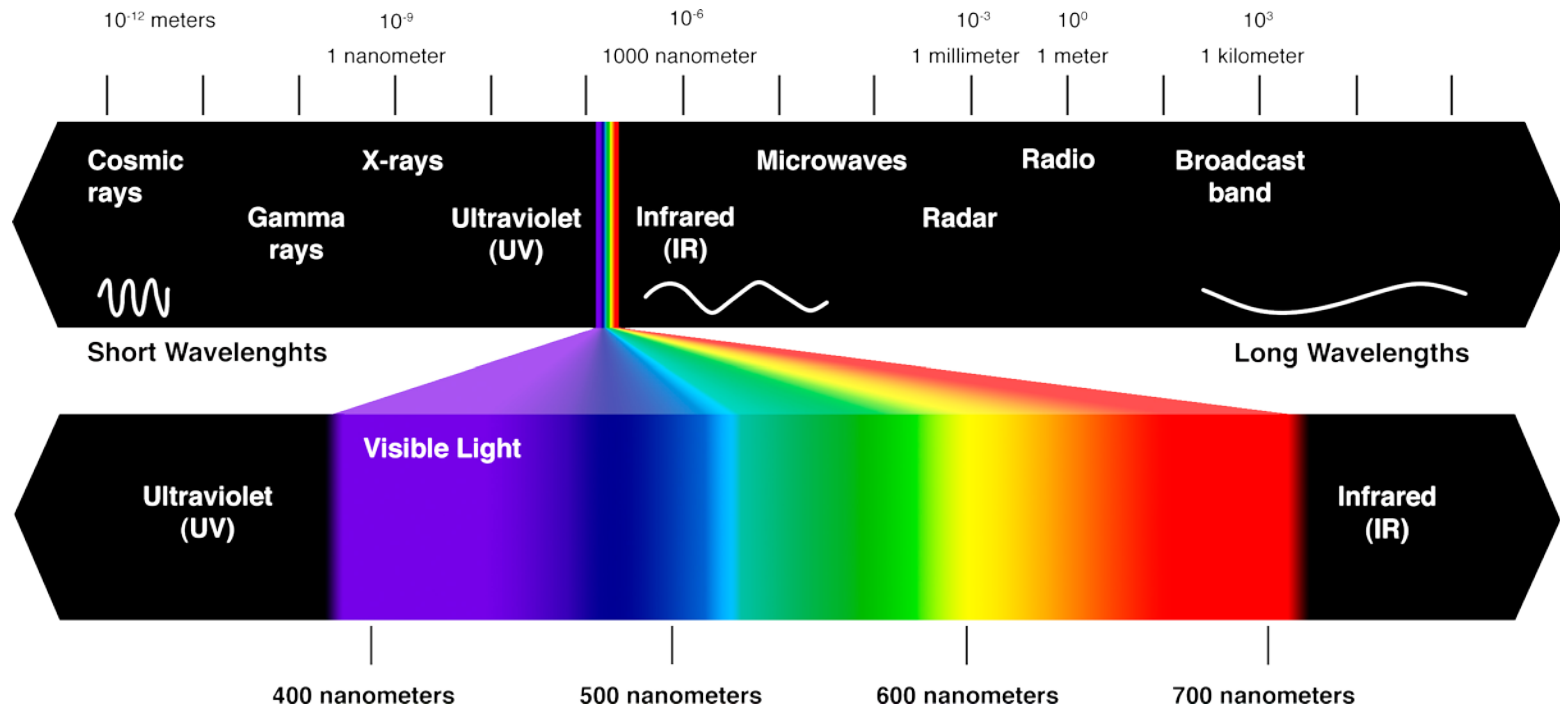

## Disposizione sensori



Lineari



Matriciali

## Protocollo di comunicazione



USB



Gethernet  
IEEE803.3z



Firewire  
IEEE1392a/b



Analog &  
Frame grabber



## **Risoluzioni e frequenze**

- Nell'industria è molto importante identificare la risoluzione minima necessaria per la manipolazione dei pezzi.
- Le telecamere hanno, soprattutto nel food e nel pharma necessità particolari di frequenza nell'acquisire le immagini.

## Protezioni (1)

I robot spesso si trovano a lavorare in condizioni ambientali sfavorevoli e quindi si rende necessario anche per le telecamere avere degli accorgimenti atti a proteggerle il più possibile per garantire un ciclo di vita maggiore.

- Protezione integrale

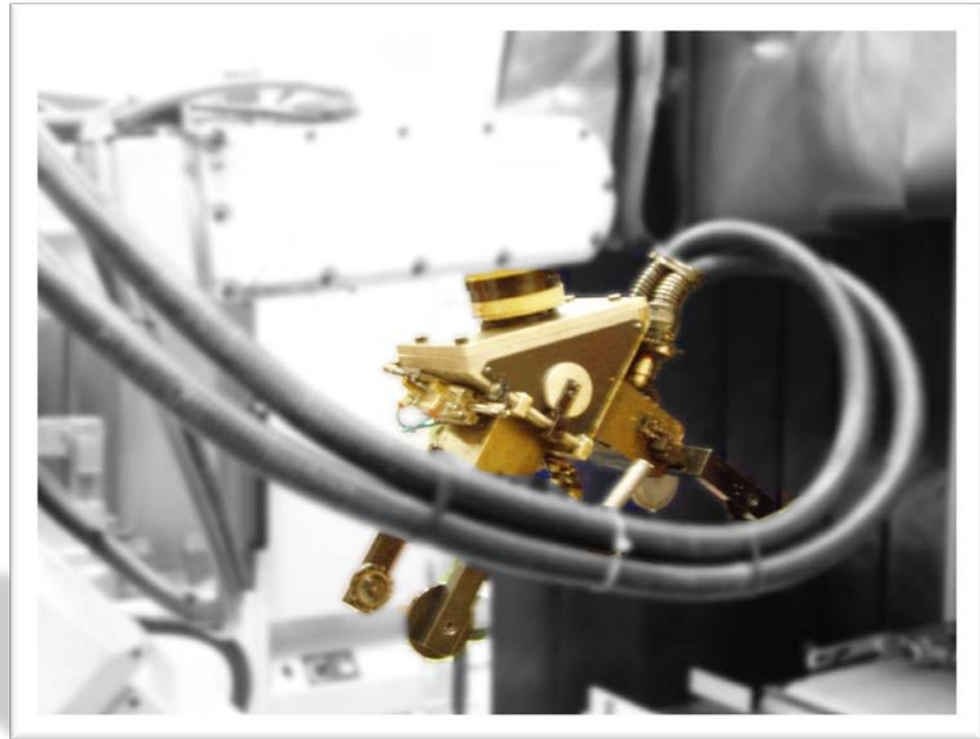











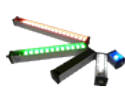



















## Protezioni (2)

- Protezioni di produzione - IP International Protection:
  - La prima cifra indica la protezione contro l'accesso di corpi solidi e contatto con parti pericolose

Livello	Dimensioni oggetto	Effetti
IP0X	Nessuna protezione	
IP1X	Protetto contro corpi solidi di dimensioni superiori a 50mm	Protetto contro l'accesso con il dorso della mano
IP2X	Protetto contro corpi solidi di dimensioni superiori a 12mm	Protetto contro l'accesso con un dito
IP3X	Protetto contro corpi solidi di dimensioni superiori a 2.5mm	Protetto contro l'accesso con un attrezzo
IP4X	Protetto contro corpi solidi di dimensioni superiori a 1mm	Protetto contro l'accesso con un filo
IP5X	Protetto contro la polvere	Protetto contro l'accesso con un filo
IP6X	Totalmente protetto contro la polvere	Protetto contro l'accesso con un filo

- La seconda cifra indica la protezione contro l'accesso di liquidi

Livello	Resistenza
IPX0	Non protetto
IPX1	Caduta verticale di gocce d'acqua
IPX2	caduta di gocce d'acqua con inclinazione massima 15°
IPX3	Pioggia
IPX4	Spruzzi
IPX5	Getti d'acqua
IPX6	Ondate
IPX7	Possibile immersione
IPX8	Possibile sommersione

HUGE ENVIRONMENT	CONFINED ENVIRONMENT	DEMANDING ENVIRONMENT	HIGH PRODUCTION RATE	WEB INSPECTION	PACKAGING	UV
<b>XBAR</b> 	<b>THINLED</b> 	<b>STAINLESS STEEL BAR</b> 	<b>BLC STROBE</b> 	<b>BLBAR</b> 	<b>DOL-I</b> 	<b>UV XBAR</b> 
<b>RING LIGHT</b> 	<b>THINLED 4 LEDS</b> 	<b>STAINLESS STEEL RING</b> 	<b>S-COAXIAL</b> 	<b>LRBAR</b> 	<b>TINYZ RGB</b> 	<b>UV RING LIGHT</b> 
<b>TINYZ</b> 	<b>TINYZ AD</b> 				<b>TUNNEL</b> 	<b>UV SBAR</b> 
<b>DOM</b> 	<b>SBAR1</b> 				<b>TUNNEL</b> 	<b>UV SPOT</b> 
<b>BL</b> 	<b>SPOT</b> 					<b>UV COAX</b> 
<b>BLGC</b> 	<b>BLC</b> 					<b>UV DOM</b> 
<b>CDGC</b> 	<b>COAXIAL</b> 					
<b>CD</b> 						

## Un semplice confronto



Object  
(500yen coin)



Light used:  
LFV2-70RD

Coaxial light is used and irradiated from the same angle as a camera. The background of the coin becomes brighter, and all figures on the coin become darker.



Light used:  
LDR2-132RD-LA

Low-angle ring light is used and irradiated from a low angle (object was placed in the middle of the light). Image shows completely opposite from the image viewed under coaxial light. The background of the coin becomes darker and all figures become brighter.



Light used:  
LDR-146LA-1

Low-angle ring light of one LED array is used and irradiated from right beside of the object (object was placed in the middle of the light). Edges of figures reflect thin and clearly, and stand out more.



Light used:  
LDL-34X8

Bar-light is used and irradiated from only one side. Figures of 500yen inside two big zeros are showed up clearly in which invisible by human eye in normal light.



Light used:  
LDL-34X8

The same Bar-light as left-hand side is used, and irradiated from the opposite direction. 500yen figure in zero disappears and one vertical line shows up instead in each zero.

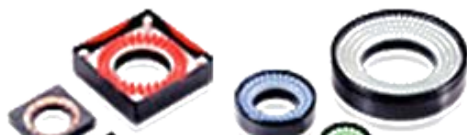
**Casi d'uso (1)**

▶ **Ring Light Units [Direct Lighting]**

These High-density Light Units are ideal for applications where irradiance must be focused at the center of the workpiece.

LDR2 Series / SQR Series /



▶ **Low-angle Ring Light Units [Direct Lighting]**

With these Light Units, the edges of the workpiece and any engraving or damage on the surfaces can be detected clearly through low-angle illumination.

LDR2-LA Series / LDR-LA-1 Series /



▶ **Bar Light Units [Direct Lighting]**

These Bar Light Units feature high-density LEDs mounted on a flat circuit board. They can be used for a wide range of applications because the illumination angle can be set freely.

LDL2 Series / LDL Series [Bar Type] / LDQ Series /



▶ **Ring Light Units [Indirect Lighting]**

These Ring Light Units achieve uniform illumination through diffused light. They are ideal for applications where the entire workpiece must be illuminated uniformly.

HPR Series / LFR Series / LKR Series /

**Casi d'uso (2)**

▶ **Low-angle Ring Light Units**  
[Indirect Lighting]

These Light Units allow the edges of the workpiece and engraving or damage on surfaces to be detected through low-angle diffused light.

FPR Series /



▶ **Low-angle Square Light Units**  
[Indirect Lighting]

These Light Units radiate diffused light from the sides of a square case. They are ideal for detecting the edges of square workpieces and engraving or damage on the surfaces.

FPQ Series /



▶ **Flat Light Units** [Indirect Lighting]

These Backlights are designed to illuminate workpieces from the back. They are ideal for external appearance photography or penetration photography.

TH Series / LDL Series [Flat Type] / LFL Series / LDL-TP Series /



▶ **Flat Dome Light Units** [Indirect Lighting]

Uniform diffused-light irradiation is achieved with these Dome Light Units through CCSiÇs unique illumination technology. Coaxial epi-illumination and dome lighting are achieved with one unit.

LFX2 Series / LFX Series /

**Casi d'uso (3)**

► **Dome Light Units [Indirect Lighting]**

These Light Units uniformly radiate the entire surface of curved glossy workpieces without creating shadows.

HPD Series / LDM2 Series /



► **Coaxial Light Units [Indirect Lighting]**

Mirrored surfaces or highly reflective workpieces can be illuminated uniformly with these Coaxial Light Units. They are ideal for photographing scratches and dents, or characters.

LFV Series / LFV2 Series / LFV2-CP Series /  
LFV2-5 Series / LNV Series /



► **Coaxial Light Units [Collimated Lighting]**

These Coaxial Light Units radiate collimated light that is ideally suited for photographing minute scratches and dents or characters on reflective surfaces, such as CDs or wafers.

MSU Series / MFU Series /



► **Line Light Units [Indirect Lighting]**

Line Light Units are ideally suited for taking pictures with a line sensor camera. The irradiance, uniformity, and length can be selected according to the application.

LND Series / HLND Series / LT Series /



**Casi d'uso (4)**

▶ **Line Light Units [Convergent Lighting]**

These Line Light Units radiate light that is converged into a straight line by using cylindrical lenses.

[LN Series](#) /



▶ **Compact Spotlights [Indirect Lighting]**

Light weight, compactness, and low power consumption are features of these Spotlights, which are applicable to a wide range of applications.

[HLV2-14 Series](#) / [HLV2-22 Series](#) / [HLV2-22-3W Series](#) / [HLV-14 Series](#) / [HLV-24 Series](#) / [HLV-24-3W Series](#) / [LV Series](#) /



▶ **Spotlights [Indirect Lighting]**

These Spotlights enable uniform illumination focused in the required range. They are ideal for replacing halogen floodlights.

[HSL Series](#) / [LSP-41](#) /



▶ **LED Light Sources**

These LED Light Sources can replace halogen light sources. The low power consumption and long life reduces the load on the environment.

[PFB2 Series](#) / [PFB-20SW Series](#) /

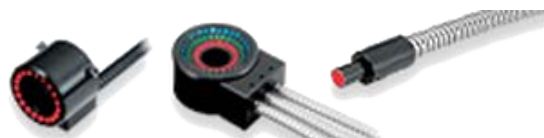
**Casi d'uso (5)**

► **Fiber Heads**

These LED Fiber Heads were developed through CCSiÇs unique light convergence technology. The product lineup includes Straight and Ring-type Fiber Heads.

[HFS Series](#) / [HFR Series](#) /



► **Light Sources for Fiber Heads**

These Light Sources for Fiber Heads are lightweight, compact, and consume less power. Full-color Light Sources are also included in the lineup.

[HLV2-22-NR-3W Series](#) / [HLV2-3M-RGB-3W](#) /  
[HLV-24-NR Series](#) / [HLV-24-NR-3W Series](#) /  
[HLV-3M-RGB-3W](#) /



► **UV Light Units [Ultraviolet Lighting]**

Uses an original LED with a peak emission wavelength of 365nm. Ideal for various types of photography using the difference in the scattering rate.

[UV Series](#) /



► **IR Light Units [Infrared Lighting]**

Select a peak emission wavelength from 850 and 940nm. These Light Units are deal for various types of photography in which light must penetrate the object.

[IR Series](#) /

**Tecnologia**

Neon High Frequency

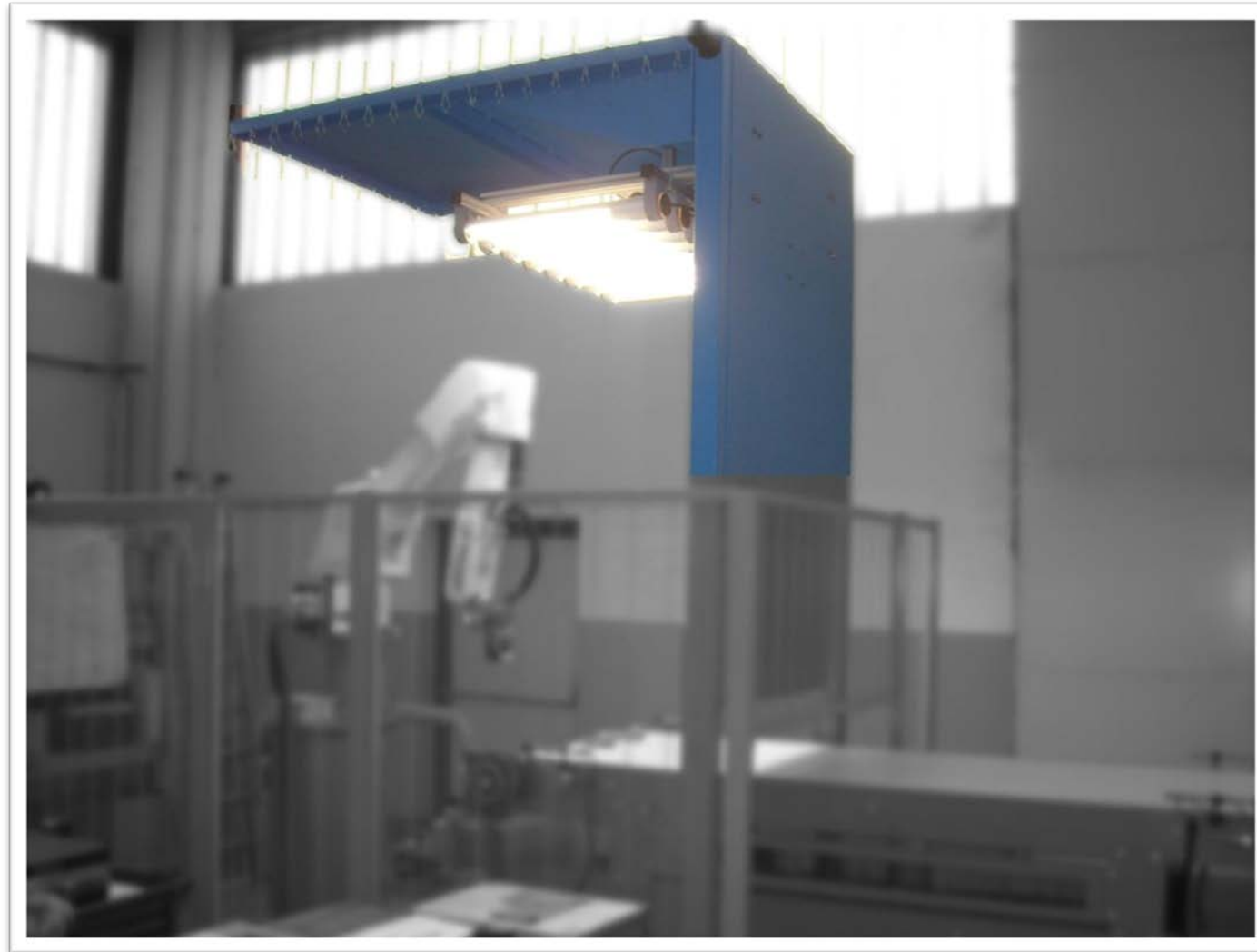

## Tecnologia (2)

### LED:

- Visibile:
  - Rosso
  - Blu
  - Verde
  - Bianco
- Non visibile
  - IR
  - Ultravioletto

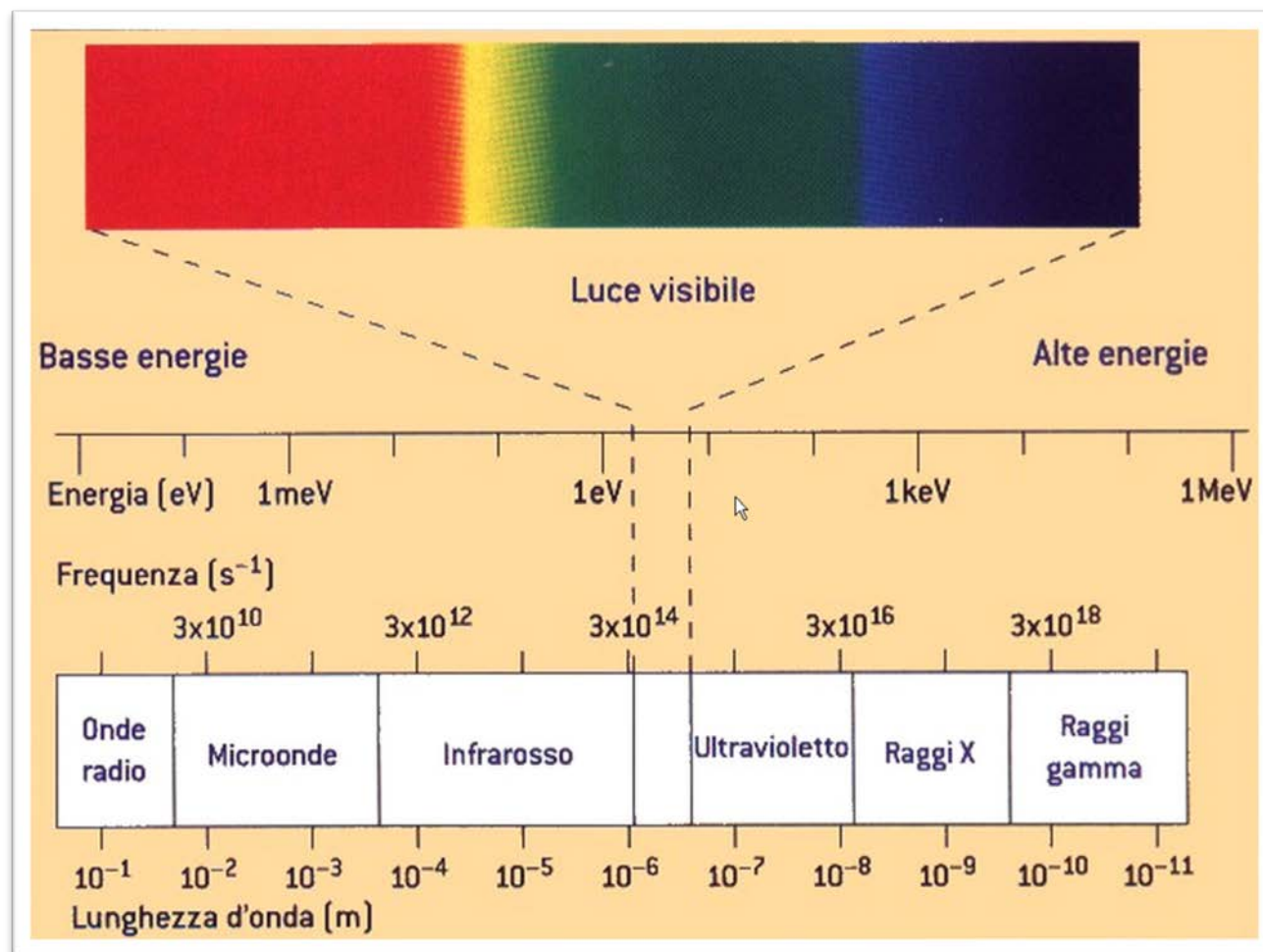

**Forme**

Ring



Barre

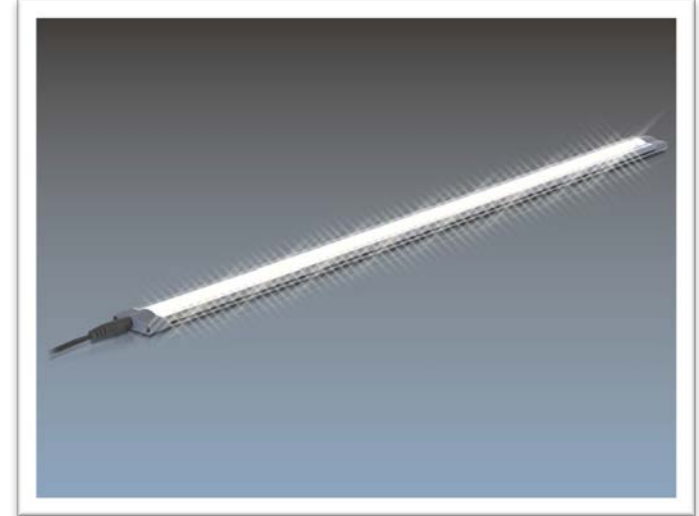

Piani



## Frequenze campionamento

- **Fissa:** ...
- **Strobo:**
  - per avere picchi di potenza nel periodo di aperture dell'otturatore (valore di picco superiore al valore medio)
  - per gestire acquisizioni con diversi colori o per illuminare da diverse posizioni

## Installazione

Retroilluminazione



Diretta



Diffusa



A raso



## Embedded

Sono quei sistemi integrati nelle telecamere, facili da utilizzare ed economici ma poco flessibili.

Utili per chi deve fare una sola applicazione e quindi non deve investire risorse temporali nell'apprendere un linguaggio di programmazione e le librerie di visione.

- Cognex
- Keyence
- Omron
- Tattile
- Dalsa
- ...



## Librerie

Sono delle librerie software che permettono agli sviluppatori di crearsi i propri sistemi di visione.

Sono poco adatte per persone che necessitano di realizzare pochi impianti, sono fondamentali per gli integratori e per chi ha particolari necessità.

- MVTech Halcon
- Cognex Vision PRO
- Keyence
- Matrox
- Nation Instrument
- Omron
- Tattile
- Dalsa
- . . .

Nei processi industriali basati su visione artificiale è fondamentale individuare cosa cercare nell'immagini acquisite della telecamere.

- Pezzi
- Forma
- Estrazione dati importanti
- Colore
- Posa
- Campo libero limitrofo
- Misure dimensionali

## **2D**

In funzione di ciò che deve essere preso e dalla sua posizione è possibile scegliere una o l'altra tipologia.

**2D:** si usa quando è noto a priori il piano su cui si trovano i pezzi da manipolare (Z) mentre sono incognite solo la posa posizione X, Y e l'orientamento  $\alpha$ . Necessita di una sola telecamera

**2D $\frac{1}{2}$  & 3D**

Il 2D  $\frac{1}{2}$  e il 3D sono usati quando non sono noti a priori la distanza Z e gli altri angoli dell'orientamento  $\beta$  e  $\gamma$ .

**2D $\frac{1}{2}$ :** monocamera + sensore esterno che da la profondità

- Laser
- Ultrasuoni
- Tastatore meccanico
- ...

**3D:** quando si usano più viste di telecamere

- 2 o più telecamere disposte nello spazio e che inquadrano la medesima zona da angoli diversi nello stesso momento
- Una telecamere montata sul robot che inquadra la stessa zona da angoli diversi in momenti diversi

## Configurazioni

- **Endpoint Open Loop (EOL):** il sistema di visione osserva solo il target. L'accuratezza nel posizionamento dell'end effector rispetto al target dipende dall'accuratezza della relazione cinematica tra telecamera ed end effector.
- **Endpoint Closed-Loop (ECL):** il sistema di visione osserva sia il target, sia l'end effector. L'accuratezza nel posizionamento dell'end effector rispetto al target non dipende dall'accuratezza della relazione cinematica tra telecamera ed end effector

## Architetture di controllo: classificazioni (1)

Si possono classificare i sistemi di controllo di visione secondo diverse tassonomie. Una prima distinzione risponde alla seguente domanda:

*La struttura di controllo è gerarchica, ovvero il sistema di visione definisce i setpoint per gli anelli di controllo di posizione a più basso livello, oppure il controllore servo visivo calcola direttamente i comandi agli attuatori?*

- Nel primo caso: **dynamic look and move.**
- Nel secondo caso: **visual servoing diretto.**

## Architetture di controllo: classificazioni (2)

Vantaggi della tecnica **dynamic look and move**:

- i bassi tempi di campionamento del segnale visivo non compromettono le prestazioni del controllo posizionale.
- in molte architetture di controllo è consentito intervenire solo a livello dei setpoint dei controllori di posizione.
- il robot viene visto dal sistema di controllo visivo come un posizionatore ideale nello spazio operativo.

## Architetture di controllo: classificazioni (3)

Una seconda distinzione risponde alla seguente domanda:

*Il segnale errore è definito in termini di coordinate 3D (nello spazio operativo) o direttamente in termini di image features?*

- Nel primo caso: controllo **position based**.
- Nel secondo caso: controllo **image based**.



## Architetture di controllo: classificazioni (4)

- Nell'approccio **position based**, le feature estratte dall'immagine sono usate, in connessione con un modello geometrico del target e con il modello della telecamera, per stimare la postura del target rispetto alla telecamera.
- L'approccio **image based**, in cui l'uscita del controllore di visione è prodotta direttamente sulla base dell'errore nel piano immagine, può ridurre i ritardi di calcolo, la necessità di interpretazione dell'immagine, e può eliminare gli errori dovuti alla modellazione del sensore di visione e alla calibrazione della telecamera. Il progetto del controllore però si complica, per effetto delle non linearità del sistema.



**HALCON**

the Power of Machine Vision



© 2003-2010 MVTec Software GmbH

**MVTec**

**3D software technologies and applications**

**DENSO**

**Thank you for your  
attention!**



**K.L.A.IN.**robotics

**ing. Fabio Tampalini Ph.D.**  
senior technical manager

**DENSO**

**K.L.A.IN. Robotics S.r.l. a socio unico**  
Sede Operativa: Via Cacciamali, 67 • 25125 Brescia, Italy  
Sede Legale: Via F.lli Porcellaga, 3 • 25122 Brescia, Italy  
Tel +390303582154 • Fax +390302659911  
Cell +393467309686  
www.klainrobotics.com  
ftampalini@klainrobotics.com

